



HOISTS FOR EVERY SPACE

209-DI INSTALLATION / OWNERS MANUAL

TWO POST HOIST

Capacity: 4 TONNE

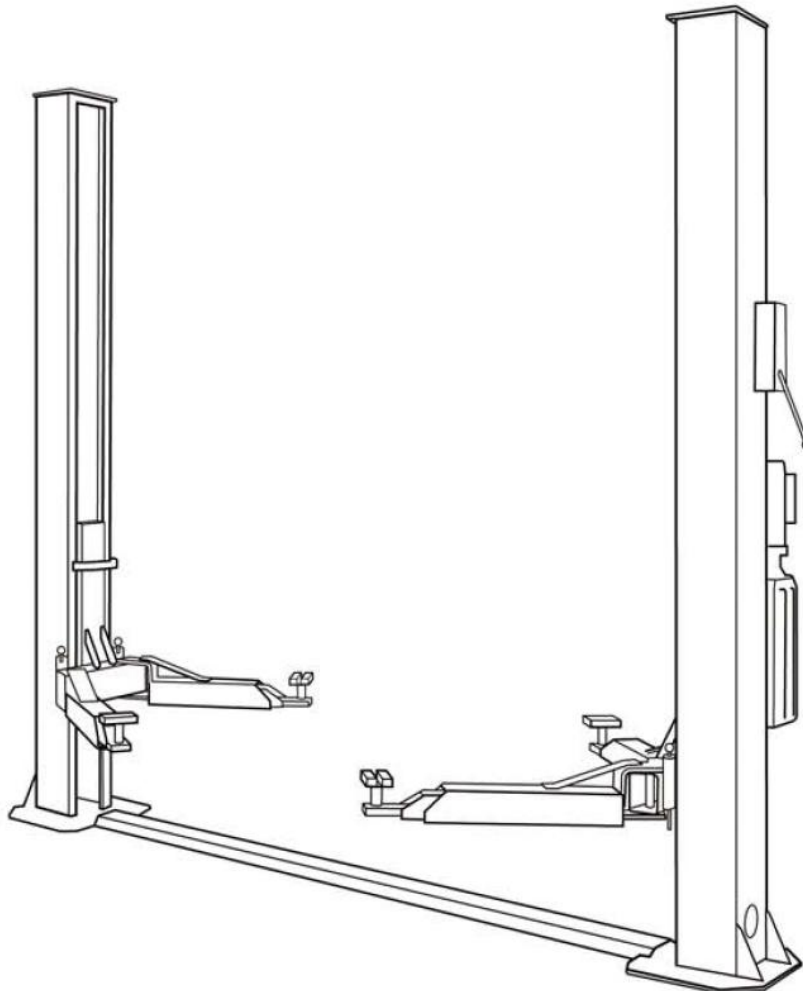

Read this manual thoroughly before installing, operating, or maintaining this lift. When done with installation be sure to return documents to package and give all materials to lift owner/operator. When installation is complete be sure to run lift up and down a few cycles with and without "typical" vehicle loaded on lift.

CONTENTS

Product Features and Specifications.....	4
Installation Requirement.....	6
Steps of Installation.....	7
Exploded View	12
Test Run.....	15
Operation Instruction.....	17
Maintenance.....	18
Trouble Shooting	19
Parts List.....	20

I. PRODUCT FEATURES AND SPECIFICATIONS

FLOORPLATE CHAIN-DRIVE TWO POST LIFT

Model BP- 9000 (See Fig. 1)

- Dual hydraulic cylinders with high quality
- Self-lubricating UHMW Polyethylene sliders and bronze bush
- Single-point safety release, and dual safety design
- Supersymmetric (2 in 1) arms design, make lifts easily find the lift point of the car
- Adjustable and screwed rubber pad as standard

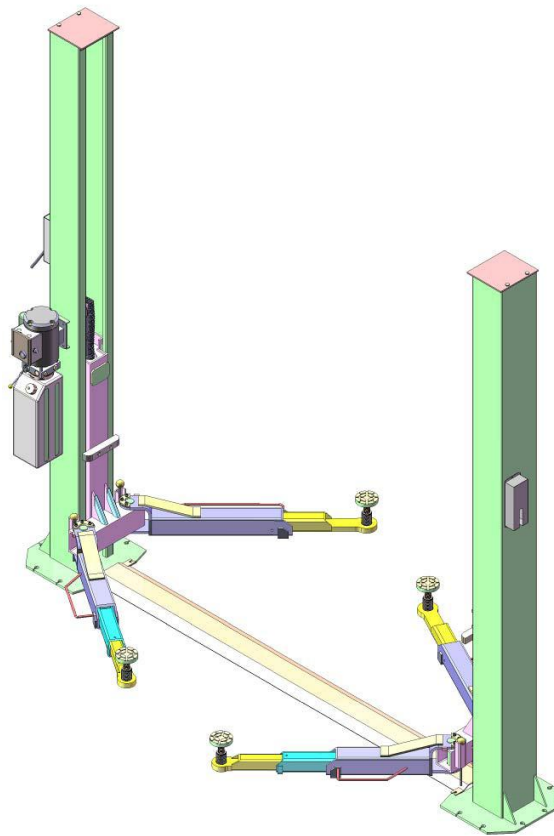

Fig. 1

MODEL BP- 9000 SPECIFICATIONS

Model	Syle	Lifting Capacity	Lifting Time	Lifting Height	Overall Height	Overall Width	Width Between Posts	Minimum Pad Height	Motor
BP-9000	Floorplate Chain-drive	4.0 T 9,000 lbs	45 S	1970 - 2080mm 77-1/2" ~ 82"	2837 mm 111-3/4"	3458 mm 136-1/8"	2850 mm 112-1/4"	120 mm 4-3/4"	2.5/3.0 HP

Arm Swings View (For BP- 9000)

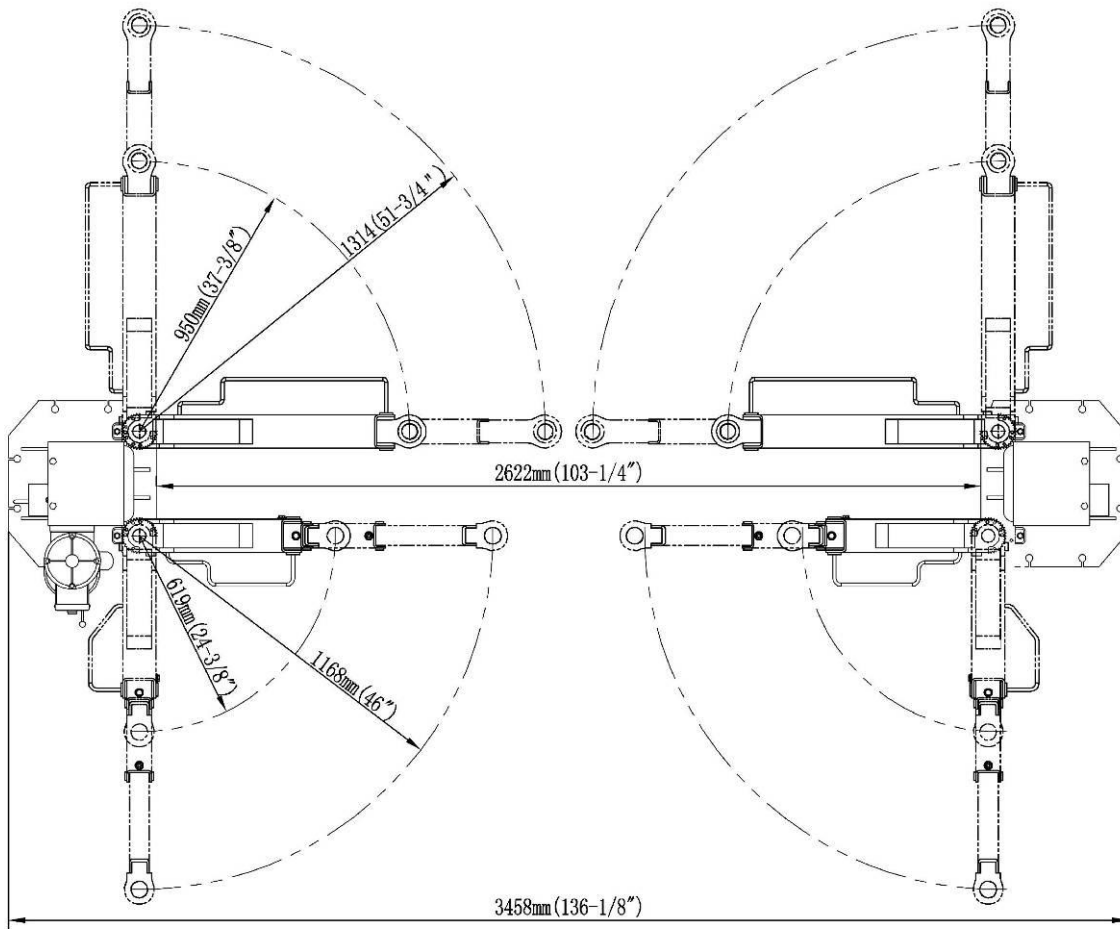

Fig. 2

II. INSTALLATION REQUIREMENT

A. TOOLS REQUIRED

- ✓ Rotary Hammer Drill ($\Phi 19$)
- ✓ Hammer
- ✓ Foot Level
- ✓ English Spanner (12")(305mm)
- ✓ Ratchet spanner with socket (10[#], 13[#], 14[#], 15[#], 17[#], 19[#], 24[#], 27[#], 30[#])
- ✓ Spanner with socket (5[#], 6[#])
- ✓ Carpenter's Chalk
- ✓ Screw Sets
- ✓ Tape Measure(7.5m)
- ✓ Pliers
- ✓ Lock Wrench

B. SPECIFICATIONS OF CONCRETE(See Fig. 3)

SPECIFICATIONS OF CONCRETE MUST BE ADHERED TO THE SPECIFICATIONS AS FOLLOWING. FAILURE TO DO SO MAY RESULT IN LIFT AND/OR VEHICLE FALLING.

1. Concrete must be thickness 150mm minimum and without reinforcing steel bars, and must be dried totally before the installation.
2. Concrete must be in good condition and must be of test strength 3,000 psi (220kg/cm²) minimum.
3. Floors must be level and no cracks.

C. POWER SUPPLY

The capacity of power must be 2.2KW, 25A minimum. The line must be 2.5mm² minimum and in good condition of contacting with floor.

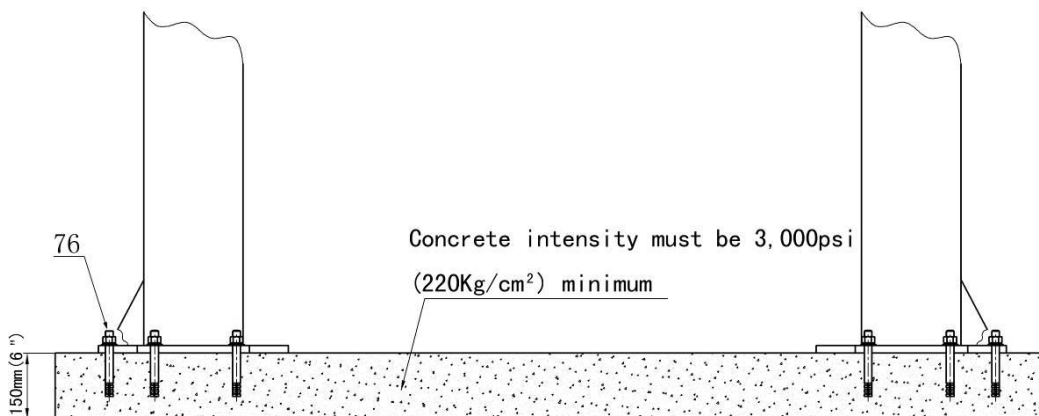

Fig. 3

III. STEPS OF INSTALLATION

A. Location of Installation

Check and insure the installation location (concrete, layout, space size etc.) is suitable for lift installation.

B. Use a carpenter's chalk line to establish installation layout of baseplate (See Fig. 4).

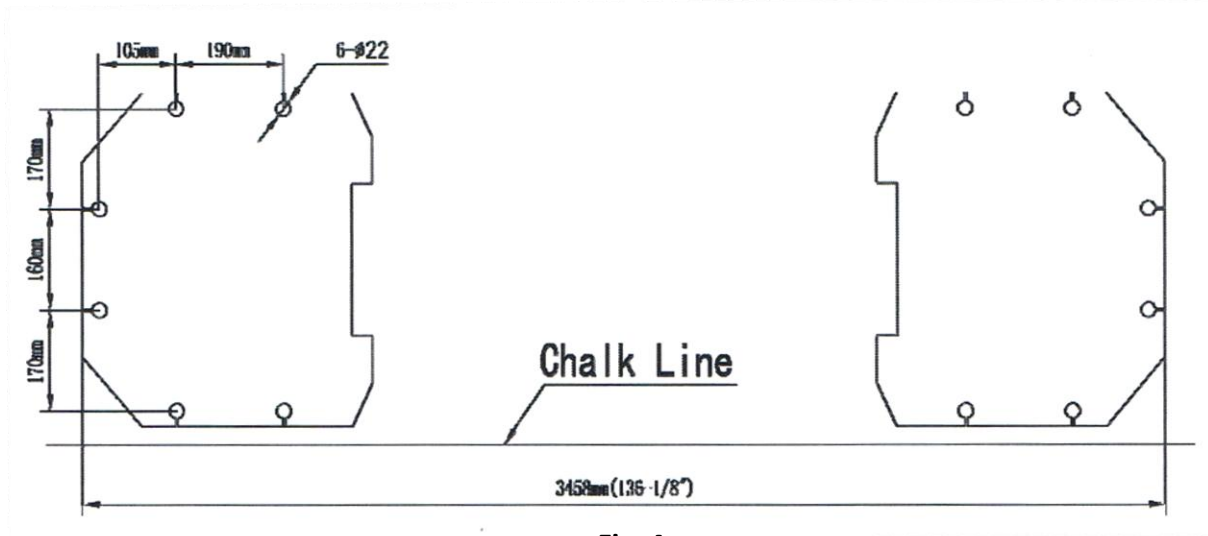
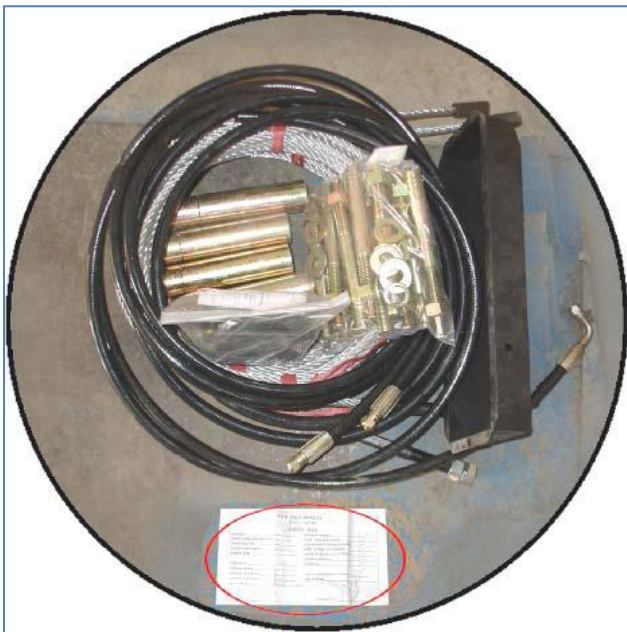

Fig. 4

C. Check the Parts Before Assembly

1. Move aside the lift with forklift or hoist, and open the outer packing carefully, and check the parts according to the shipment parts list.
2. Open the carton of parts and check the parts according to parts box list. (see picture 1)
3. Check the parts of the parts bag according to parts bag list. (see picture 2)



Picture. 1



Picture. 2

D. Position Powerside Post

Lay down two posts on the installation site parallelly, position the Powerside Post according to the actual installation environment. Usually, it is suggested to install Powerside Post on the front-right side from which vehicles are driven to the lift.

E. Assembly

Install Topplate, Oil Hose Assy.

Note: The direction of Hydraulic Cylinder Fitting and the connection of the Oil Hose Assy. should be in accordance with the sketch maps of Hydraulic System (See Fig. 5). Otherwise, the Oil Hose Would be damaged by the Lifting Head.

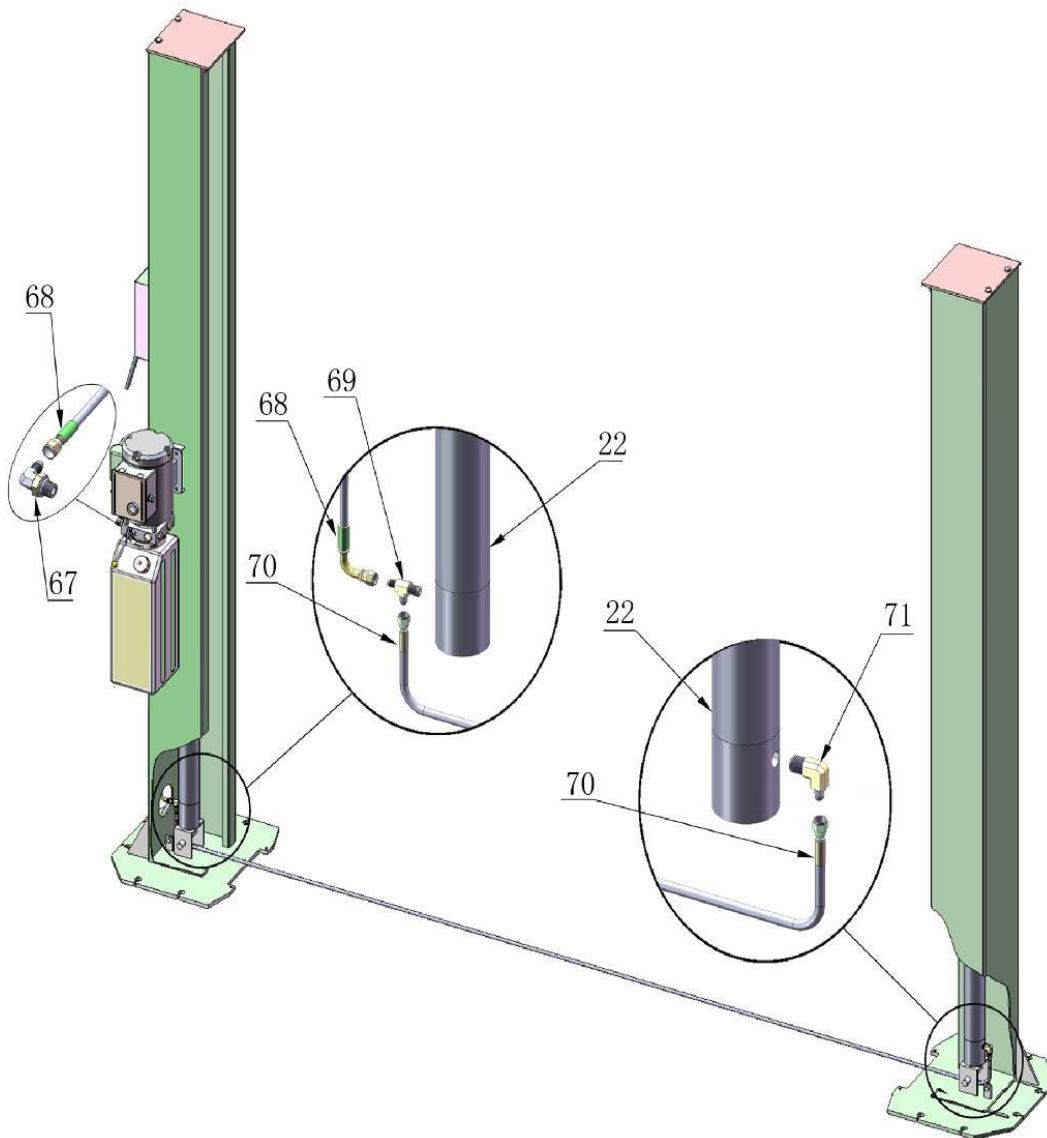

Fig. 5

F. Install Cable (see Fig. 6)

Note: The Cable should go through the inner lifing head.

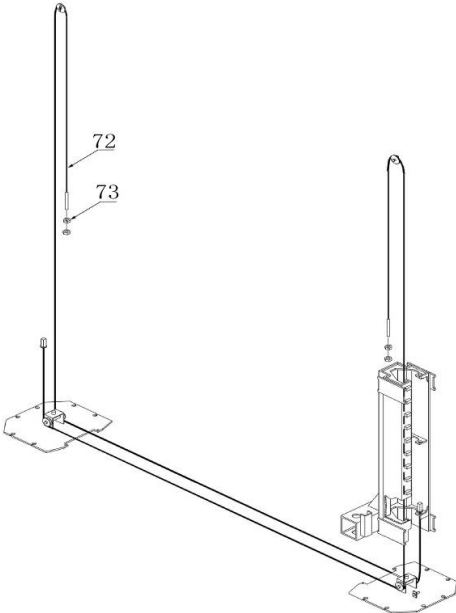

Fig. 6

G. Install Safety Device and Safety cable (See Fig. 7)

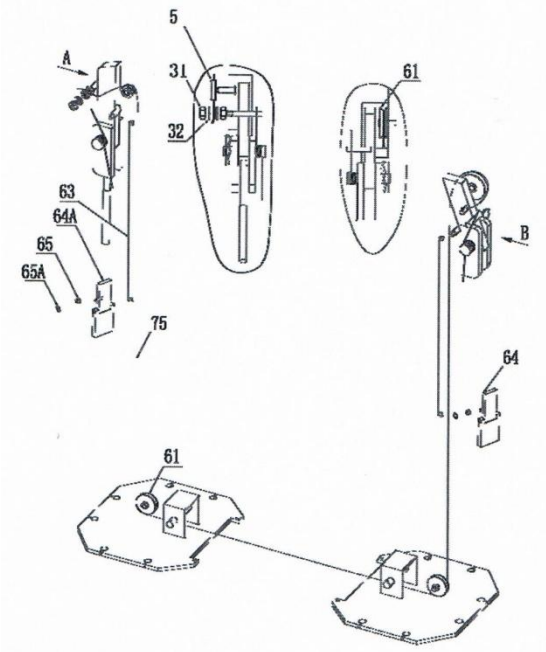

Fig. 7

H. Fix the two Posts

Position posts, making sure their positions are conformed to the chalkline. **(See Fig. 4)**

Using the prescribed rotary hammer drill, and drill all the anchor holes and install the anchor bolts. Make the posts level and plumbness with each other using the shims, and tighten the Anchor Bolts **(See Fig. 8)**

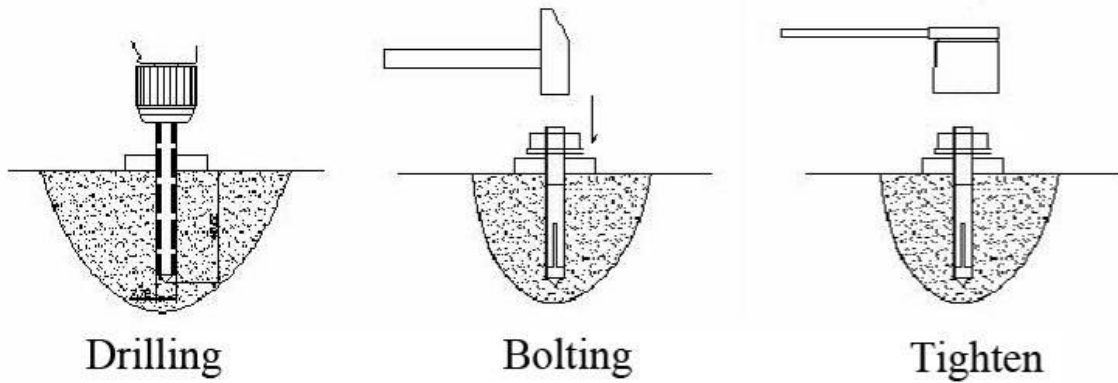
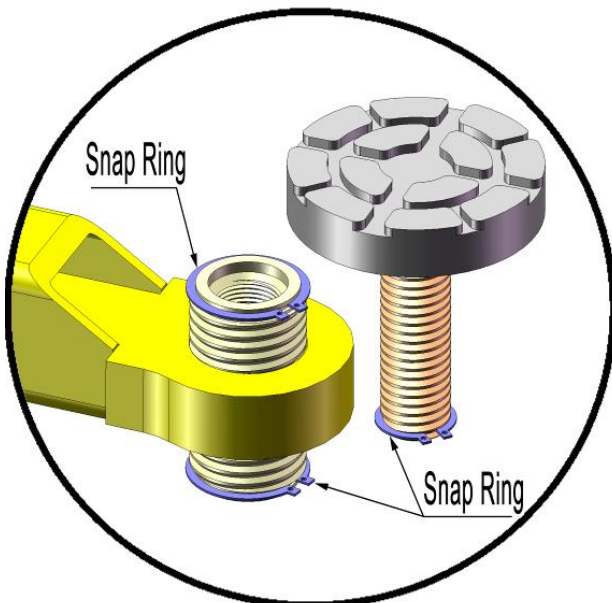

Fig. 8

I. Install Lifting Arms and Pads ...

Install the Lifting Arms, Lift Pads and Snap Rings **(See Picture 3, 4)**; Attach the Power Unit to the Powerside Post, connect the Oil hoses and tighten all the hydraulic fittings, and fill the tank with Hydraulic Oil. **(Note: In consideration of Power Unit's durability and keep the equipment running in the perfect condition, please use Hydraulic Oil 46#)**



Picture 3

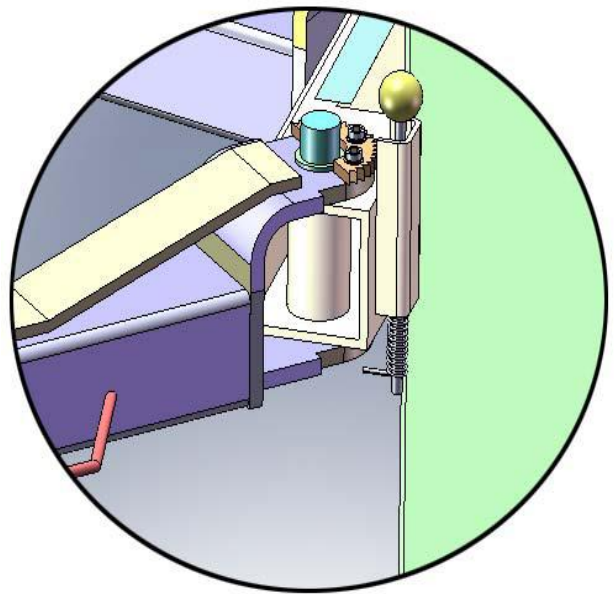

Picture 4

J. Install Electrical System (See Fig. 9)

Connect the power source as per the data plate of the Power Unit. make sure the connection of the limit switch is correct

(Note: For the safety of operators, the power wiring must contact the floor well. Pay attention to the direction of rotations when using 380V, three phase motors).

Fig. 9

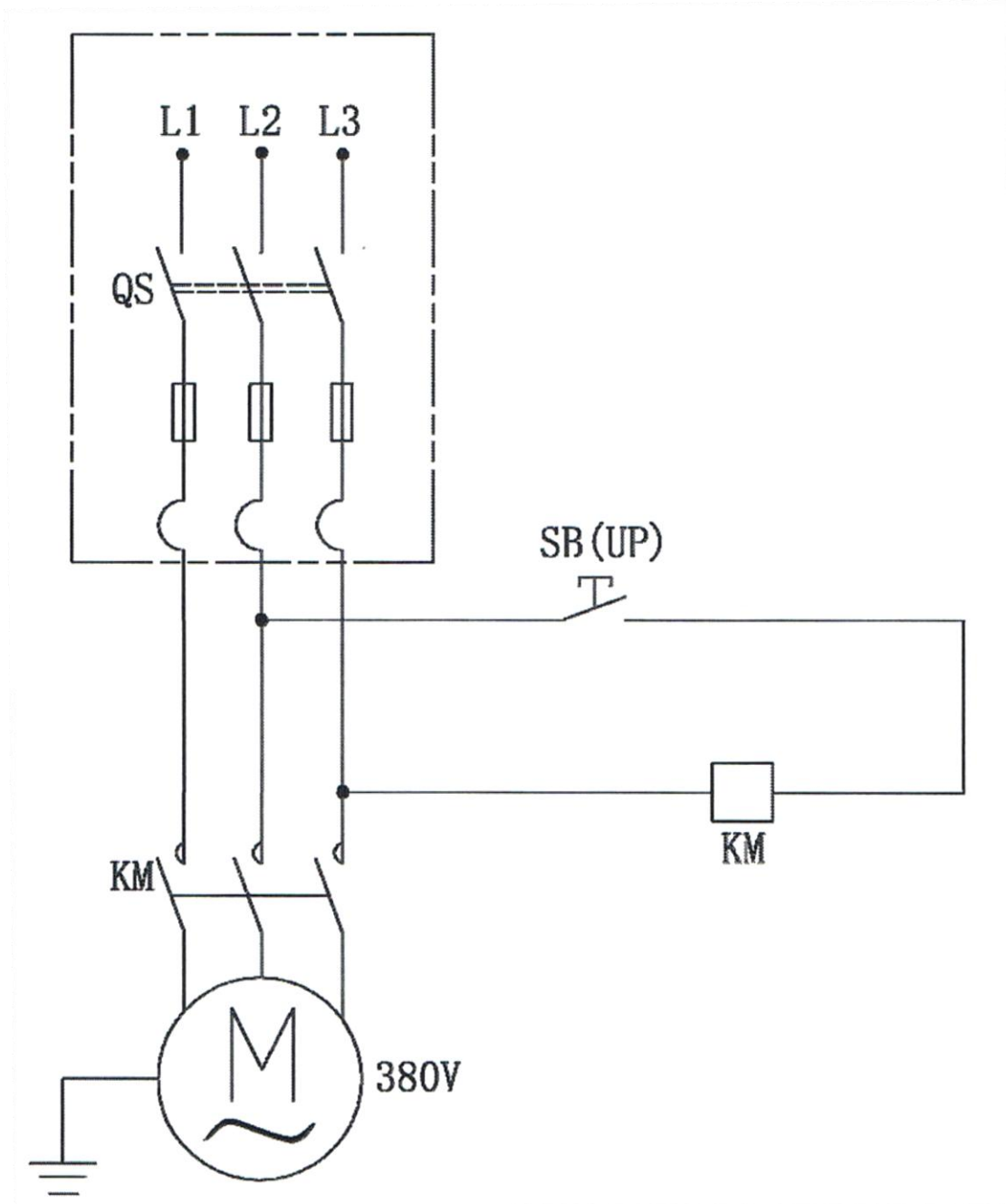

IV. EXPLODED VIEW

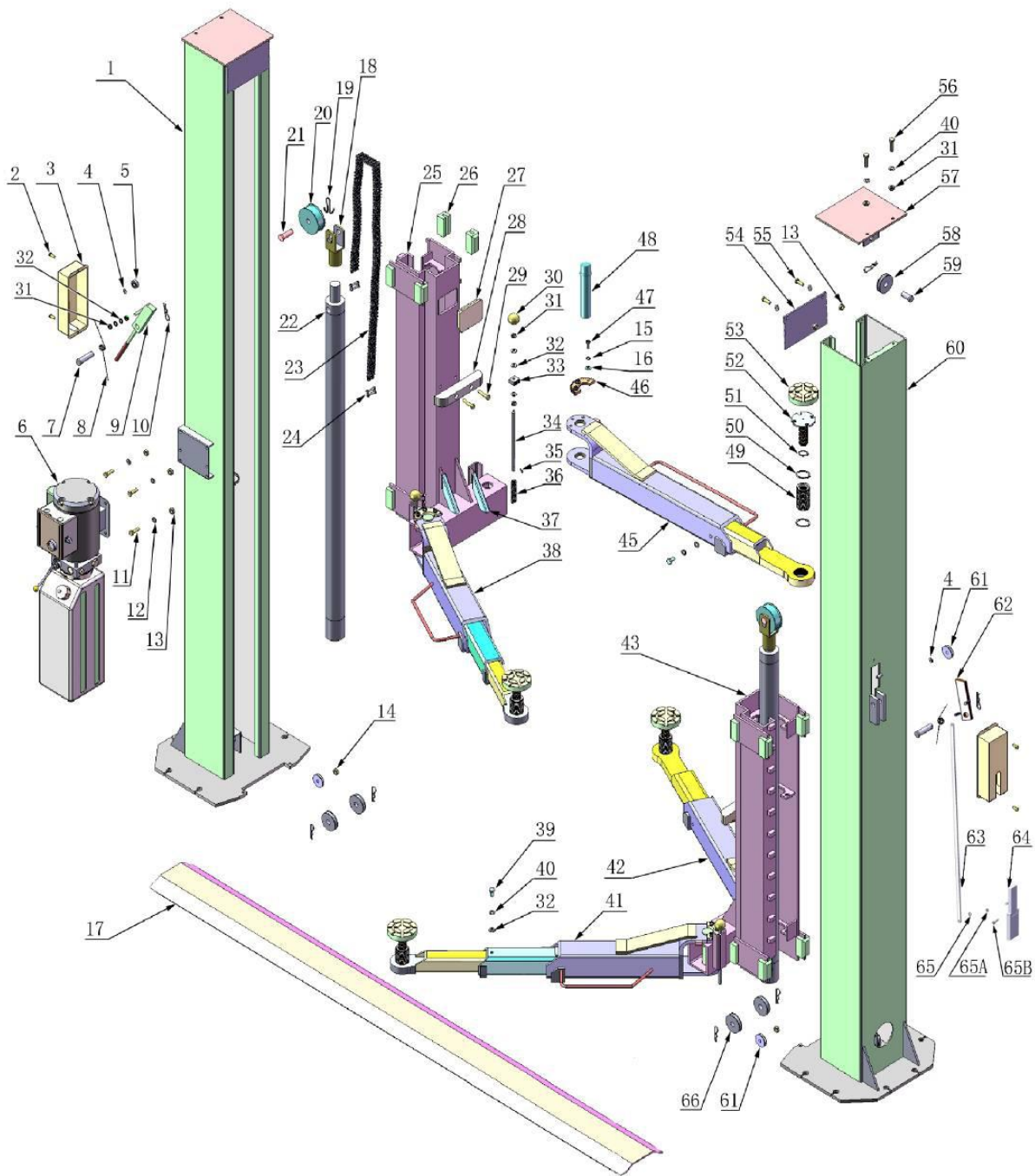
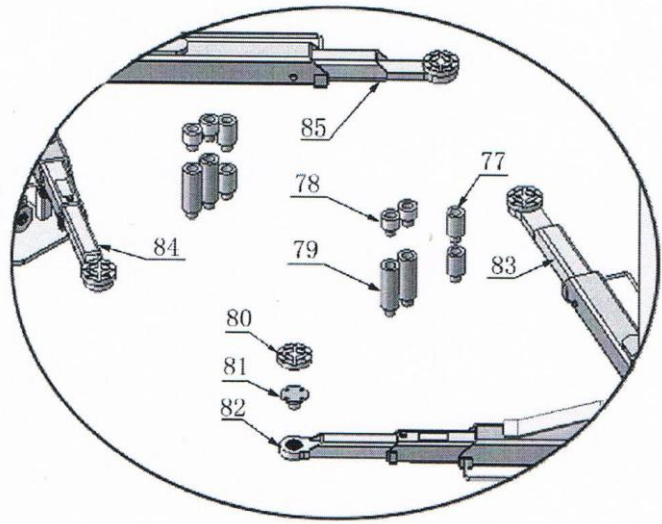

Fig. 10



More Choice !

The stackable adapters package with 1.5" (38mm), 3" (76mm), 6" (152mm) and compatible arms are available for option

Cylinders

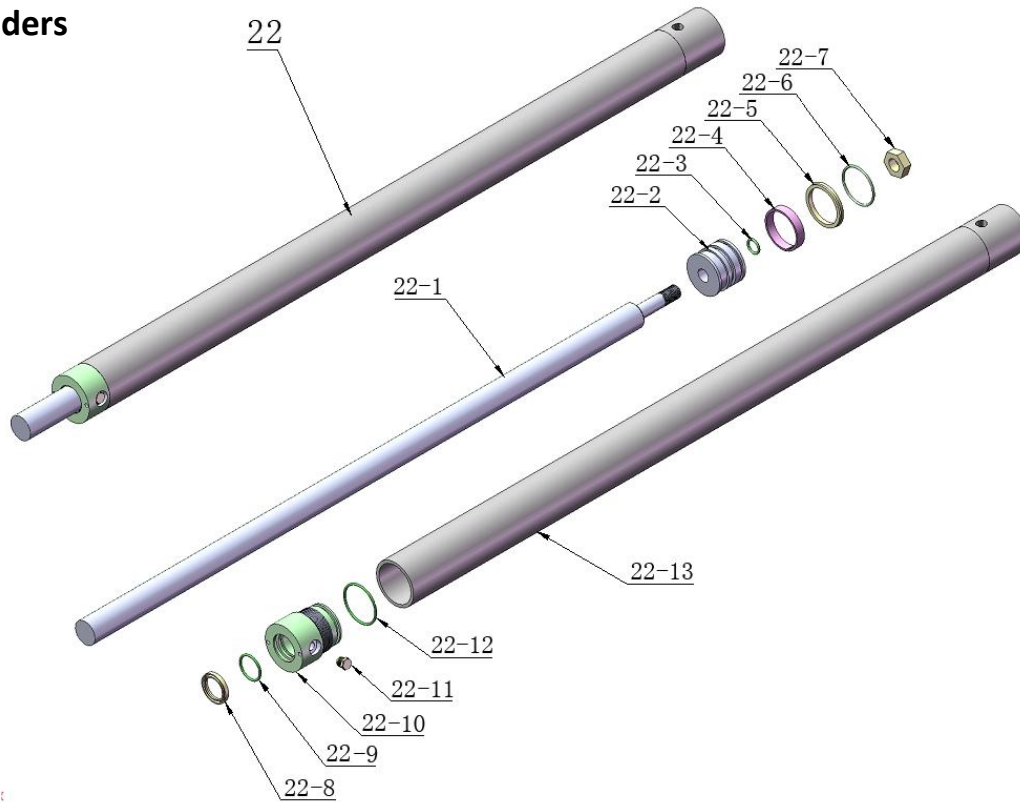

Fig. 11

Hydraulic Power Unit

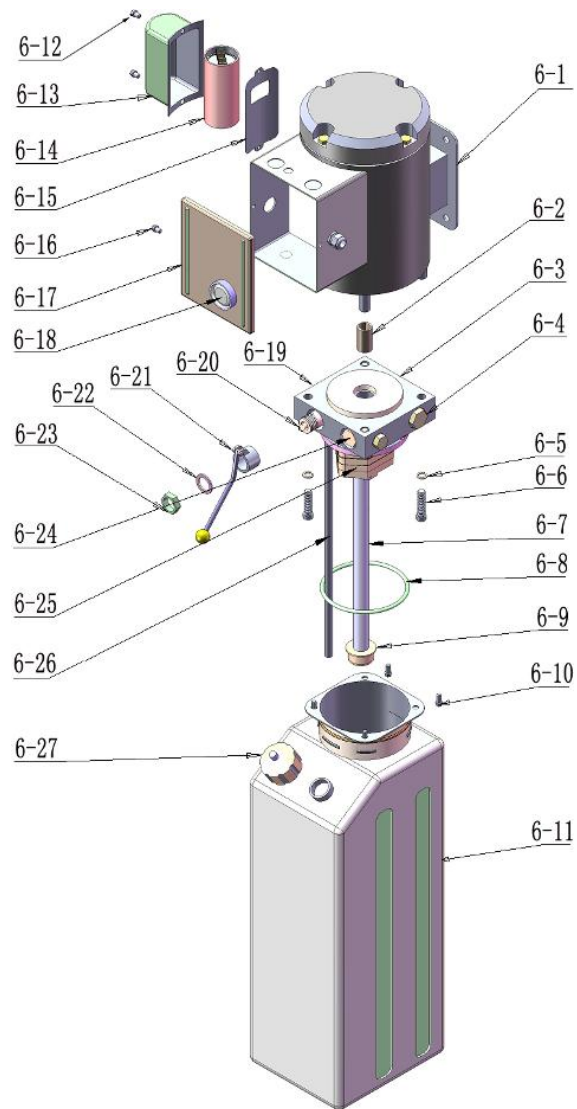
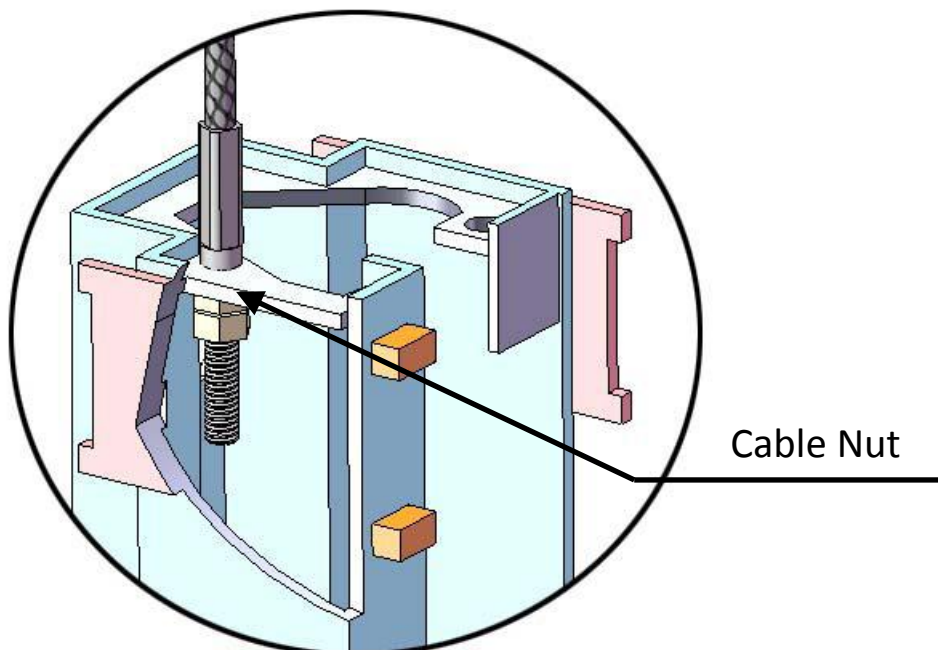

Fig. 12

V. TEST RUN

1. Adjust Synchronous Cable

Press **UP** button to lift the carriage up to the first safety lock position then press **DOWN** button to lock the carriages. Use Spanner to hold the cable fitting, meanwhile use 24[#] Ratchet spanner to tighten the cable nut. Make sure two Cables are with the same tension so that two Lifting Heads can work synchronously (See **Picture 5**)



Picture 5

2. Adjust Safety Cable

Lifting the carriage and lock at the same height, strain the Safety Cable and then release a little, and then tighten the cable screw. Make sure the Safety Device can always be worked properly.

3. Adjust the lower speed

You can adjust the lower speed of the lift as required: loosen the Fixing Nut of the Throttle Valve, and then turn the Throttle Valve clockwise to decrease the lower speed, or counter clockwise to increase the lower speed. Do not forget to tighten the Fixing Nut after the lower speed adjustment has been done.

Note: For some power unit, the lower speed is fixed at factory and can't be adjustable.

4. Test with load

After finishing the above adjustment, test running the lift with load. Run the lift in low position for several times first, make sure the lift can rise and lower synchronously, the Safety Device can lock and release synchronously. And then test run the lift to the top completely. If there are anything improper, repeat the above adjustment.

NOTE:It will shake when running the lift without load at the first time,but running it with load for a few times, the air would be exhausted and shaking will be disappeared automatically.

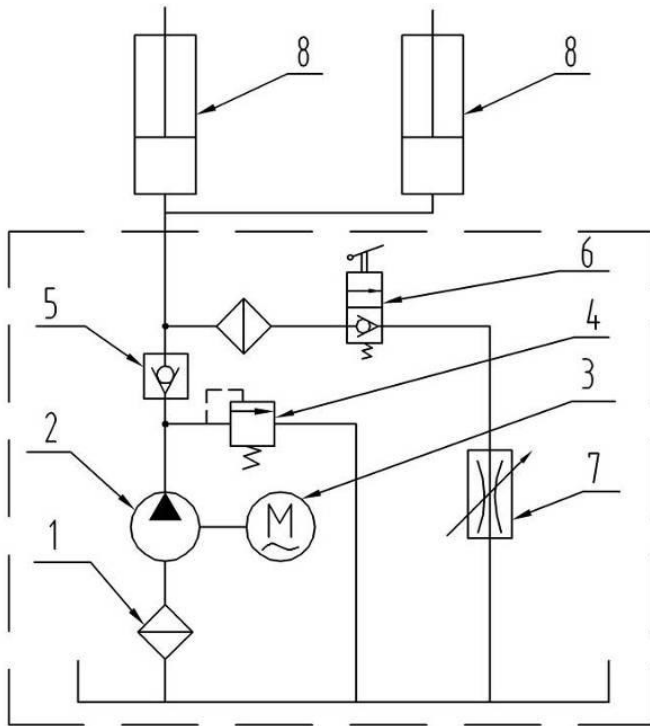

- N
O
T
E**
1. Filter
 2. Gearpump
 3. Motor
 4. Relief Valve
 5. Check Valve
 6. Release Valve
 7. Throttle Valve
 8. Hydraulic Cylinder

Fig. 13 Hydraulic System

VI. OPERATION INSTRUCTIONS

Please read the lift safe instruction carefully before using the machine.

To lift vehicle

1. Keep clean of environment near the lift;
2. Position lift arms to the lowest position;
3. To shortest lift arms;
4. Open lift arms;
5. Position vehicle between columns;
6. Move arms to the vehicle's lifting point;

Note: The four lift arms must at the same time contact the vehicle's lifting point where manufacturers recommended

7. Press the **UP** button until the lift pads contact underside of vehicle totally. Recheck to make sure vehicle is secure;
8. Continue to raise the lift slowly to the desired working height, ensuring the balance of vehicle;
9. Push lowering handle to lower lift onto the nearest safety. The vehicle is ready to repair.

To lower vehicle

1. Be sure clear of around and under the lift, only leaving operator in lift area;
2. Press the button of **UP** to raise the vehicle slightly, and then release the safety device, lower vehicle by pushing lowering handle.
3. Open the arms and position them to the shortest length;
4. Drive away the vehicle.

VII. MAINTENANCE SCHEDULE

Monthly:

1. Re-torque the anchor bolts to 80-117 Nm;
2. Check all connectors, bolts and pins to insure proper mounting;
3. Lubricate cable with lubricant;
4. Make a visual inspection of all hydraulic hoses/lines for possible wear or leakage;
5. Check Safety device and make sure proper condition;
6. Lubricate all Rollers and Pins with 90wt. Gear oil or equivalent;

Note: All anchor bolts should take full torque. If any of the bolts does not function for any reason, DO NOT use the lift until the bolt has been replaced.

Every six months:

1. Make a visual inspection of all moving parts for possible wear, interference or damage.
2. Check and adjust as necessary, equalizer tension of the cables to insure level lifting.
3. Check columns for plumbness.
4. Check Rubber Pads and replace as necessary.
5. Check Safety device and make sure proper condition.

VIII. TROUBLE SHOOTING

TROUBLE	CAUSE	REMEDY
Motor does not run	<ol style="list-style-type: none"> 1. Button does not work 2. Wiring connections are not in good condition 3. Motor burned out 4. Height Limit Switch is damaged 5. AC contactor burned out 	<ol style="list-style-type: none"> 1. Replace button 2. Repair all wiring connections 3. Repair or replace motor 4. Replace the Limit Switch 5. Replace AC Contactor
Motor runs but the lift is not raised	<ol style="list-style-type: none"> 1. Motor runs in reverse rotation 2. Gear Pump out of operation 3. Release Valve in damage 4. Relief Valve or Check Valve in damage 5. Low oil level 	<ol style="list-style-type: none"> 1. Reverse two power wire 2. Repair or replace 3. Repair or replace 4. Repair or replace 5. Fill tank
Lift does not stay up	<ol style="list-style-type: none"> 1. Release Valve out of work 2. Relief Valve or Check Valve leakage 3. Cylinder or Fittings leaks 	<ol style="list-style-type: none"> 1. Repair or replace
Lift raises slowly	<ol style="list-style-type: none"> 1. Oil line is jammed 2. Motor running on low voltage 3. Oil mixed with air 4. Gear Pump leaks 5. Overload lifting 	<ol style="list-style-type: none"> 1. Clean the oil line 2. Check Electrical System 3. Fill tank 4. Replace Pump 5. Check load
Lift can not lower	<ol style="list-style-type: none"> 1. Safety device are in activated 2. Release Valve in damage 3. Safety cable broken 4. Oil system is jammed 	<ol style="list-style-type: none"> 1. Release the safeties 2. Repair or replace 3. Replace 4. Clean the oil system

IX. Parts List (See Fig. 10)

Item.	Part No.	Description	Qty.	Note
1	201001	Powerside Post	1	
2	209009	Cup Head Bolt	4	
3	209008	Safety Cover	2	
4	209010	Snap Ring	2	
5	209011	Pulley	1	
6	209002	Hydraulic Power Unit	1	
7	209006	Safety Pin	2	
8	209007	Safety Spring	2	
9	203002	Powerside Safety Assy.	1	
10	209012	Hair Pin	8	
11	209003	Hex Bolt	4	
12	209004	Rubber Ring	4	
13	209005	Nylok Nut	12	
14	209056	Nylok Nut	2	
15	209034	Spring Washer	12	
16	209033	Washer	12	
17	201003	Floor Cover	1	
18	201004	Chain Pulley Assy.	2	
19	201005	Split Pin	2	
20	203004	Chain Pulley	2	
21	201007	Pin For Chain Pulley	2	
22	201008	Hydraulic Cylinder	2	
23	203005	Chain	2	
24	203006	Chain Connector	4	
25	203007	Powerside Lifting Head	1	
26	206044	Slider	16	
27	209016	Carriage Plastic Cover	2	
28	206045	Protective Rubber	2	
29	206046	Bolt	4	
30	209020	Plastic Ball	4	
31	209021	Hex Nut	12	
32	209022	Washer	18	
33	209023	Teeth	4	
34	209024	Arm Lock Bar	4	
35	209025	Hair Pin	4	
36	209026	Spring	4	
37	209027	Protective Rubber Sets	4	
38	201012	Lifting Arm – Front Right (3-Stages)		

Item.	Part No.	Description	Qty.	Note
38A	201012A	Mid - Lifting Arm – Front Right	1	
38B	201012B	Inner Lifting Arm – Front Right	1	
39	209038	Hex Bolt	6	
40	209039	Lock Washer	14	
41	201013	Lifting Arm – Front Left (3-Stage)	1	
41A	201013A	Mid - Lifting Arm – Front Left	1	
41B	201013B	Inner Lifting Arm – Front Left	1	
42	201014	Lifting Arm – Rear Left (2-Stage)	1	
42A	201014A	Inner Lifting Arm – Rear Left	1	
43	201015	Offside Lifting Head	1	
44	201016 A	Inner Lifting Arm – Rear Right (2-Stage)	1	
45	201016	Lifting Arm – Rear Right	1	
46	209035	Gear	4	
47	209032	Socket Bolt	12	
48	209030	Lifting Arm Pin	4	
49	206034	Outer Screw	4	
50	206033	Snap Ring	8	
51	206032	Snap Ring	4	
52	206031	Inner Screw	4	
53	209041	Rubber Pad	4	
54	203009	Connecting Bar	2	
55	209043	Hex Bolts	4	
56	209046	Hex Bolts	4	
57	203010	Top plate	2	
58	209045	Big Pulley	2	
59	209044	Pin for Pulley	2	
60	203011	Offside Post	1	
61	209049	Plastic Pulley	3	
62	203012	Offside Safety Assy.	1	
63	203013	Coupling	2	
64	203014	Safety Block (Second Side)	1	
64A	203015	Safety Block (Main Side)	1	
65	203016	Snap Ring	2	
65A	203017	Shim	2	
65B	203018	Socket Bolts	4	
66	209057	Small Pulley	4	

Item .	Part No.	Description	Qty.	Note
Oil Hose, Fitting & Cable (See Fig. 5)				
67	209060	90 ⁰ Fitting for Hydraulic Power Unit	1	
68	201021	Oil Hose	1	
69	201022	T-Fitting	1	
70	203019	Oil Hose	1	
71	201020	90 ⁰ Fitting	1	
72	201022	Cable	2	
73	201024	Cable Nut	4	
74	209067	Cup Head Bolt	1	
75	203021	Safety Cable	1	
76	209059	Anchor bolts	12	

Item.	Part No.	Description	Qty.	Note
Optional Arm Kits (See Fig. 10)				
77	209052	Stackable Adapter (3")	4	
78	209051	Stackable Adapter (1.5")	4	
79	209053	Stackable Adapter (6")	4	
80	209041	Rubber Pad	4	
81	209040	Lifting Pad Weldment	4	
82	201013C	Inner Lifting Arms - Front Left	1	
83	201014B	Inner Lifting Arms - Rear Left	1	
84	201012C	Inner Lifting Arms - Front Right	1	
85	201016B	Inner Lifting Arms - Rear Right	1	

Item.	Part No.	Description	Qty.	Note
Hydraulic Cylinder (see Fig. 11)				
22-1	201027	Piston Rod	2	
22-2	201028	Piston	2	
22-3	206069	O-Ring	2	
22-4	201029	Support Ring	2	
22-5	201030	Y-Ring	2	
22-6	201031	O-Ring	2	
22-7	206071	Hex Nut	2	
22-8	209078	Dust Seal	2	
22-9	201032	O-Ring	2	
22-10	201033	Head Cap	2	
22-11	201034	Bleeding Plug	2	
22-12	201035	O-Ring	2	
22-13	201036	Bore Weldment	2	

Item .	Part No.	Description	Qty.	Note
Parts For Hydraulic Power Unit (See Fig 12.)				
6-1	209082	Motor	1	
6-2	209083	Motor Connecting Shaft	1	
6-3	209084	Valve Body	1	
6-4	209085	Relief Valve	1	
6-5	209086	Spring Washer	4	
6-6	209087	Socket Bolt	4	
6-7	209088	Inlet Pipe	1	
6-8	209089	O-Ring	1	
6-9	209090	Filter	1	
6-10	209091	Hex bolt	4	
6-11	209092	Reservior	1	
6-12	209093	Bolt	2	
6-13	209094	Cover of Capacitor	1	
6-14	209095	Capacitor	1	
6-15	209096	Rubber Gasket	1	
6-16	209097	Hex bolt	1	
6-17	209098	Cover of Motor Terminal Box	1	
6-18	209099	Push Button	1	
6-19	209100	Oil Outlet	1	
6-20	209101	Release Valve	1	
6-21	209102	Handle For Release Valve	1	
6-22	209103	Washer	1	
6-23	209104	Hex Nut	1	
6-24	209105	Check Valve	1	
6-25	209106	Gear Pump	1	
6-26	209107	Oil Return Pipe	1	
6-27	209108	Filler Cap	1	

